

Ring functionalized cyclopentadienyl derivatives of niobium and tantalum: molecular structures of $(\eta^5\text{-C}_5\text{H}_4\text{-CO}_2\text{CH}_3)\text{M}(\text{CO})_4$ where $\text{M} = \text{Nb}$ and Ta and $(\eta^5\text{-C}_5\text{H}_4\text{-CO}_2\text{CH}_2\text{C}_6\text{H}_5)\text{Nb}(\text{CO})_4$

Thomas E. Bitterwolf^{a,*}, Skip Gallagher^a, Arnold L. Rheingold^b, Glenn P.A. Yap^b

^a Department of Chemistry, University of Idaho, Moscow, ID 83844-2343, USA

^b Department of Chemistry, University of Delaware, Newark, DE 19716, USA

Received 23 July 1996; received in revised form 12 March 1997

Abstract

Reaction of $\text{Na}[\text{M}_2(\mu\text{-Cl})_3(\text{CO})_8]$, where $\text{M} = \text{Nb}$ or Ta , with $\text{NaC}_5\text{H}_4\text{R}$, where $\text{R} = \text{COCH}_3$, CO_2CH_3 , $\text{CO}_2\text{C}_2\text{H}_5$, COC_6H_5 , $\text{COCH}_2\text{C}_6\text{H}_5$, $\text{LiC}_5\text{H}_4\text{C}(\text{CH}_3)\text{CH}_2$, or NaC_9H_7 gives the corresponding $(\eta^5\text{-C}_5\text{H}_4\text{R})\text{M}(\text{CO})_4$, or $(\eta^5\text{-C}_9\text{H}_7)\text{M}(\text{CO})_4$ compounds in good yield. $\text{NaC}_5\text{H}_4\text{COCH}_2\text{C}_6\text{H}_5$, a new cyclopentadienyl synthon, was used to prepare $\text{TiC}_5\text{H}_4\text{COCH}_2\text{C}_6\text{H}_5$, and $(\eta^5\text{-C}_5\text{H}_4\text{COCH}_2\text{C}_6\text{H}_5)\text{Mn}(\text{CO})_3$. The latter was fully characterized as a model compound for the new ligand. The niobium and tantalum compounds are air-stable as solids but readily undergo oxidation in solution. Compounds were characterized by IR, ^1H and ^{13}C NMR spectroscopies, and elemental analyses. Molecular structures of three compounds were determined. $(\eta^5\text{-C}_5\text{H}_4\text{CO}_2\text{CH}_3)\text{Nb}(\text{CO})_4$: monoclinic, $P2_1/c$, $a = 12.664(6)$ Å, $b = 6.390(3)$ Å, $c = 15.355(9)$ Å, $\beta = 97.81(4)^\circ$, $V = 1231(1)$ Å³, $Z = 4$, and $R(F) = 3.90\%$. $(\eta^5\text{-C}_5\text{H}_4\text{CO}_2\text{CH}_3)\text{Ta}(\text{CO})_4$: monoclinic, $P2_1/c$, $a = 12.612(4)$ Å, $b = 6.399(1)$ Å, $c = 15.273(6)$ Å, $\beta = 97.89(3)^\circ$, $V = 1220.9(4)$ Å³, $Z = 4$, and $R(F) = 5.67\%$. $(\eta^5\text{-C}_9\text{H}_7)\text{Nb}(\text{CO})_4$: monoclinic, $P2_1/c$, $a = 16.353(2)$ Å, $b = 7.959(1)$ Å, $c = 12.778(4)$ Å, $\beta = 106.14(2)^\circ$, $V = 1597.7(6)$ Å³, $Z = 4$, and $R(F) = 2.48\%$. © 1997 Elsevier Science S.A.

1. Introduction

The last several years have seen a renewal of interest in the synthesis of ring functionalized cyclopentadienyl metal compounds as new techniques and reagents have emerged. In addition to the fundamental interest in the functionalized compounds themselves, these materials have been used as building blocks in polymers [1,2], and in modifying the solubility of complex organometallic moieties [3–5]. Missing from the expanding catalog of functionalized materials have been the $(\eta^5\text{-C}_5\text{H}_4\text{R})\text{M}(\text{CO})_4$, where $\text{M} = \text{Nb}$ and Ta .

A survey of the literature suggests that only $(\eta^5\text{-C}_5\text{H}_5)\text{M}(\text{CO})_4$, $(\eta^5\text{-C}_5\text{H}_4\text{CH}_3)\text{M}(\text{CO})_4$, and $(\eta^5\text{-C}_5\text{Me}_5)\text{M}(\text{CO})_4$ [6,7], where $\text{M} = \text{Nb}$ and Ta and $(\eta^5\text{-C}_9\text{H}_7)\text{Nb}(\text{CO})_4$ [8] have been reported. In most cases these compounds are prepared by reductive carbonylation (under extremely high pressure conditions) of the corresponding $(\eta^5\text{-C}_5\text{H}_4\text{R})\text{MCl}_4$ compounds [9]. In one

case $(\eta^5\text{-C}_5\text{H}_5)\text{M}(\text{CO})_4$ was prepared by reaction of $[\text{M}(\text{CO})_6]^{-1}$ with NaC_5H_5 and HgCl_2 and may proceed through the intermediacy of the neutral $\text{C}_5\text{H}_5\text{HgCl}$ species [10]. Although $(\eta^5\text{-C}_5\text{H}_4\text{R})\text{V}(\text{CO})_4$, where $\text{R} = \text{COCH}_3$ and COC_6H_5 , have been prepared by Friedel Crafts routes [11], no comparable reaction chemistry has been developed for the niobium and tantalum compounds. One study describing the complexation of AlCl_3 to the Nb in $(\eta^5\text{-C}_5\text{H}_5)\text{Nb}(\text{CO})_4$ suggests that conventional Friedel Crafts techniques may be complicated by side reactions [12].

Several years ago Calderazzo, Pampaloni and their coworkers [13] described the synthesis of $\text{Na}[\text{M}(\text{CO})_6] \cdot \text{THF}$, where $\text{M} = \text{Nb}$ (1) and Ta (2), and their conversion to the novel reagents $\text{Na}[\text{M}_2(\mu\text{-Cl})_3(\text{CO})_8]$ which were, in turn, were allowed to react with LiC_5H_5 (Reaction 1) to prepare $(\eta^5\text{-C}_5\text{H}_5)\text{M}(\text{CO})_4$. As a large number of $\text{NaC}_5\text{H}_4\text{R}$ reagents are now available, we speculated that the Calderazzo and Pampaloni methodology might be extended to the synthesis of ring functionalized compounds of niobium and tantalum. This paper will present the results of our investigation into

* Corresponding author. Tel.: +1 208 885 6552; fax.: +1 208 885 6173; e-mail: bittert@osprey.csr.v.uidaho.edu

these reactions as well as improvements to the synthesis of the metal carbonyl reagents themselves. The synthesis of a new reagent, $\text{NaC}_5\text{H}_4\text{COCH}_2\text{C}_6\text{H}_5$, and its conversion to Nb, Ta, and Mn complexes is also described. As our attempts to carry out Friedel Crafts acylations or lithiations of $(\eta^5\text{-C}_5\text{H}_5)\text{M}(\text{CO})_4$, $\text{M} = \text{Nb}$ and Ta, have thus far been unsuccessful, the routes reported here may be the only paths to these ring functionalized compounds.

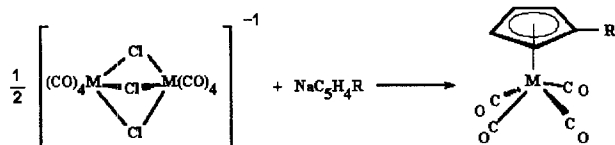

2. Results and discussion

Using a modification of the procedure described by Calderazzo and Pampaloni [13], $\text{Na}[\text{M}(\text{CO})_6] \cdot \text{THF}$, $\text{M} = \text{Nb}$ (**1**) and Ta (**2**), were prepared in excellent yield. Repeated attempts to prepare **1** and **2** by scrupulous adherence to the literature procedure were unable to achieve yields in excess of 19%. Both **1** and **2** were found to be air and light sensitive, thus they were stored in the glove box in brown bottles. Reaction of **1** or **2** with $\text{Cu}(\text{I})\text{Cl}$ in THF under an atmosphere of CO efficiently formed $\text{Na}[\text{M}_2(\mu\text{-Cl})_3(\text{CO})_8]$, $\text{M} = \text{Nb}$ (**3**) and Ta (**4**) which was confirmed by IR. These reagents were used without isolation in the subsequent reactions. The presence of a $\text{Cu}\text{-CO}$ species was also suggested by an IR band at 2093 cm^{-1} [14]. Copper-bound carbon monoxide groups are characterized by carbonyl stretching frequencies near that of free CO.

$\text{NaC}_5\text{H}_4\text{R}$ reagents were prepared via known literature routes by reaction of NaC_5H_5 with RCO_2Et or RCO_2Me [15,16]. The new reagent $\text{NaC}_5\text{H}_4\text{COCH}_2\text{C}_6\text{H}_5$, **5**, was prepared in a similar manner and characterized by ^1H and ^{13}C NMR in D_2O , as well as by synthesis of its thallium salt and $\text{Mn}(\text{CO})_3(\eta^5\text{-C}_5\text{H}_4\text{COCH}_2\text{C}_6\text{H}_5)$ derivative, **7**. **7** was fully characterized by IR, ^1H and ^{13}C NMR spectroscopies and elemental analysis. It should be noted that the proton and carbon spectra of the cyclopentadienyl unit in both the thallium salt and the manganese derivative consist of two resonances (H-2/H-5 and H-3/H-4) characteristic of rapid rotation about the $\text{Cp}\text{-COR}$ bond. In contrast, four protons and three carbon signals are observed for the ring in the spectrum of the sodium salt requiring restricted rotation about the $\text{Cp}\text{-COR}$ bond. It has been suggested that the sodium salts of acylcyclopentadienyl derivatives are best described as fulvenes in which the bulk of the negative charge resides on the

acyl oxygen. The observed solubility of these sodium salts in water may be attributable to either a solvated anion or to a protonated (or rapidly exchanging) fulvenyl alcohol of the form $\text{C}_5\text{H}_4=\text{C}(\text{OH})\text{R}$ [17].

Addition of THF solutions of $\text{NaC}_5\text{H}_4\text{R}$ reagents to solutions of freshly prepared **3** and **4** gave dark brown solutions. After no more than one hour of reaction at room temperature, the solvent was removed and the residue was taken up in benzene and chromatographed through a plug of silica gel. The resulting crude material was found to contain the desired products contaminated with an organic oil. Final purification was accomplished by a combination of recrystallizations and sublimations. In the synthesis of $(\text{indenyl})\text{Nb}(\text{CO})_4$, a solid impurity was removed from the niobium product by fractional sublimation. NMR examination revealed that this impurity was 1,1'-biindenyl [18], apparently formed by a Kharash-type coupling mediated by excess $\text{Cu}(\text{I})$ or the CuCO species. It was found that heating the $\text{Na}[\text{Nb}_2(\text{CO})_8]$ solution prior to addition of NaC_5H_7 destroyed the catalytic species giving cleaner yields of the niobium products. We now strongly suspect that the organic oils encountered as impurities in the other reactions were coupled bicyclopentadienyl species or their polymerization products.

Slow chromatography of the reaction mixtures on silica gel or alumina resulted in extensive decomposition. Although compounds were air sensitive in solution, they were air stable for several days as the solids. Analytical samples had to be sealed under argon to prevent their oxidation during transport. A number of attempts to prepare the formylcyclopentadienyl derivatives using $\text{NaC}_5\text{H}_4\text{C}(\text{O})\text{H}$ were unsuccessful.

IR and NMR spectra of compounds **8** to **21** are consistent with their formulation as seven coordinate species. There is very little variation in the carbonyl stretching frequencies across this series. Carbonyl resonances could not be observed for the niobium compounds due to coupling with the 9/2 spin Nb nucleus. In addition, the cyclopentadienyl carbon resonances of the Nb compounds were typically broadened.

20 has been previously reported by Green and Hughes from the reaction of $\text{Nb}(\eta^5\text{-C}_9\text{H}_7)_2\text{BH}_4$ with CO and trimethylamine [8]. The spectral properties reported here are identical to those of the earlier report. An attempt to prepare **20** by reductive carbonylation of $\text{Nb}(\eta^5\text{-C}_9\text{H}_7)\text{Cl}_4$ was unsuccessful.

Crystallographic quality crystals of **8**, **9**, and **16** were grown and the molecular structures of these compounds determined (see Figs. 1–3). Crystallographic data are summarized for these compounds in Table 1, while selected bond lengths and angles are presented in Tables 2 and 3. As expected, **8** and **9** are isostructural with the ester groups almost exactly coplanar with the cyclopentadienyl groups. Ta–CO bond lengths are slightly shorter than the Nb–CO bond lengths consistent with the argu-

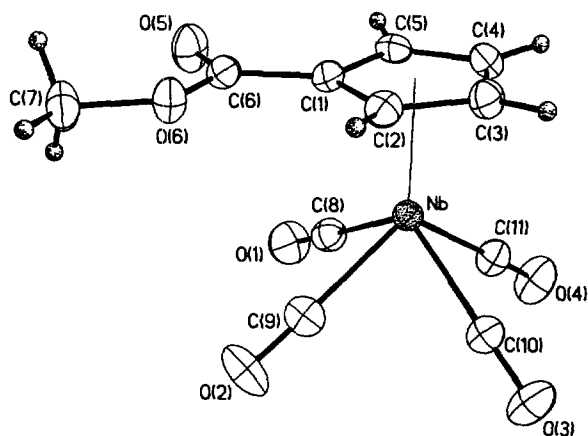
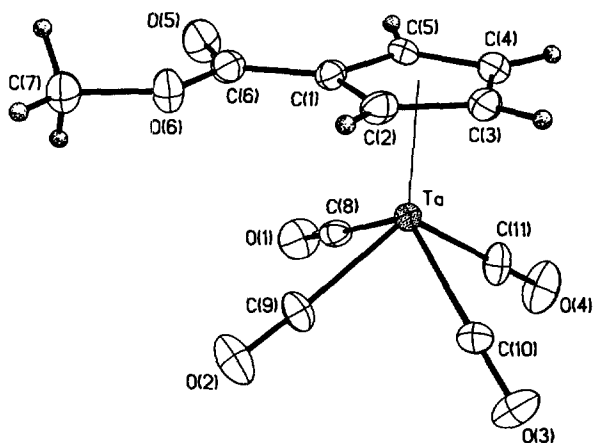
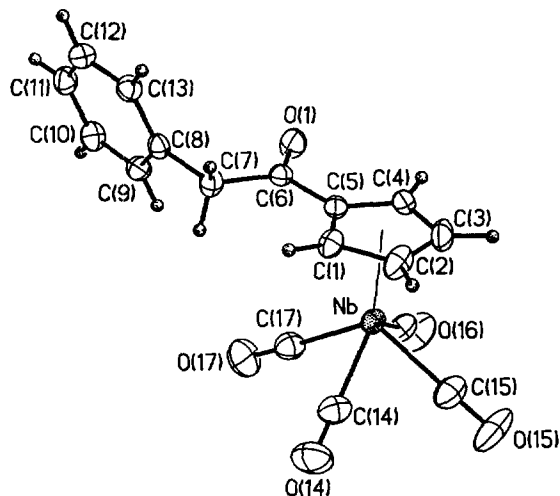
Fig. 1. Molecular structure of **8**.Fig. 2. Molecular structure of **9**.Fig. 3. Molecular structure of **10**.Table 1
Crystallographic data for **1**, **2** and **3**

	8	9	10
Formula	C ₁₁ H ₇ O ₆ Nb	C ₁₁ H ₇ O ₆ Ta	C ₁₇ H ₁₁ O ₅ Nb
Formula weight	328.1	416.1	388.2
Space group	<i>P</i> 2 ₁ / <i>c</i>	<i>P</i> 2 ₁ / <i>c</i>	<i>P</i> 2 ₁ / <i>c</i>
<i>a</i> (Å)	12.664(6)	12.612(4)	16.353(2)
<i>b</i> (Å)	6.390(3)	6.399(1)	7.959(1)
<i>c</i> (Å)	15.355(9)	15.273(6)	12.778(4)
β (deg)	97.81(4)	97.89(3)	106.14(2)
<i>V</i> (Å ³)	1231(1)	1220.9(4)	1597.7(6)
<i>Z</i>	4	4	4
Crystal color	orange red	orange	orange
<i>D</i> (calc) (g cm ⁻³)	1.788	2.264	1.614
μ(Mo Kα) (cm ⁻¹)	10.03	90.18	7.75
Temperature (K)	296	233	298
Radiation	Mo Kα (λ = 0.71073 Å)		
<i>R</i> (<i>F</i>) (%)	3.90 ^a	5.67 ^a	2.48 ^b
<i>R</i> (<i>wF</i>) (%)	4.68	6.65	6.38 ^c

^a Quantity minimized = $\sum w\Delta^2$; $R = \sum \Delta / \sum (F_0)$; $R(w) = \sum \Delta w^{1/2} / \sum (F_0 w^{1/2})$, $\Delta = |F_0 - F_c|$.

^b Quantity minimized = $R(wF^2) = \sum [w(F_0^2 - F_c^2)^2] / \sum [(wF_0^2)^2]^{1/2}$; $R = \sum \Delta / \sum (F_0)$, $\Delta = |F_0 - F_c|$.

^c $R(wF^2)$ (%).

Table 2
Selected bond lengths (Å) and angles (°) for **8** and **9**

	Nb(8)	Ta(9)
Bond lengths (Å)		
M–C(8)	2.097(5)	2.069(13)
M–C(9)	2.089(5)	2.072(13)
M–C(10)	2.087(5)	2.065(13)
M–C(11)	2.081(5)	2.081(13)
C(8)–O(1)	1.136(7)	1.157(17)
C(9)–O(2)	1.124(6)	1.117(17)
C(10)–O(3)	1.141(6)	1.142(16)
C(11)–O(4)	1.138(6)	1.132(17)
C(1)–C(6)	1.470(7)	1.475(18)
C(6)–O(5)	1.204(6)	1.192(17)
C(6)–O(6)	1.328(6)	1.333(16)
C(7)–O(6)	1.440(7)	1.450(19)
M–CNT	2.090(5)	2.070(11)
Bond Angles (°)		
C(8)–M–C(9)	73.2(2)	73.1(5)
C(9)–M–C(10)	74.4(2)	75.0(6)
C(10)–M–C(11)	73.2(2)	75.3(5)
C(8)–M–C(11)	74.9(2)	75.3(5)
C(8)–M–C(10)	118.5(2)	119.1(5)
C(9)–M–C(11)	114.5(2)	114.8(5)
C(1)–C(6)–O(6)	111.9(4)	111.3(11)
C(1)–C(6)–O(5)	124.0(5)	123.9(12)
O(5)–C(6)–O(6)	124.0(5)	124.8(13)
CNT–M–C(8)	120.3(2)	120.4(4)
CNT–M–C(9)	121.5(2)	121.8(4)
CNT–M–C(10)	121.2(2)	120.5(4)
CNT–M–C(11)	124.0(2)	123.4(4)

Table 3
Selected bond lengths (Å) and angles (°) for **16**

Bond lengths (Å)			
Nb–C(14)	2.091(4)	C(14)–O(14)	1.138(4)
Nb–C(15)	2.082(4)	C(15)–O(15)	1.135(4)
Nb–C(16)	2.082(4)	C(16)–O(16)	1.138(4)
Nb–C(17)	2.083(4)	C(17)–O(17)	1.144(4)
C(5)–C(6)	1.484(4)	C(6)–O(1)	1.208(3)
C(6)–C(7)	1.505(4)	C(7)–C(8)	1.507(4)
Nb–CNT	2.091(4)		
Bond angles (°)			
C(14)–Nb–C(15)	74.75(14)	C(15)–Nb–C(16)	73.50(14)
C(16)–Nb–C(17)	74.12(14)	C(14)–Nb–C(17)	74.84(13)
C(15)–Nb–C(17)	116.06(14)	C(14)–Nb–C(16)	118.53(14)
C(5)–C(6)–O(1)	120.8(3)	C(5)–C(6)–C(7)	116.4(3)
C(7)–C(6)–O(1)	122.8(3)	CNT–Ta–C(14)	118.9(2)
CNT–Nb–C(15)	120.8(2)	CNT–Nb–C(16)	122.5(2)
CNT–Nb–C(17)	123.2(2)		

ment above that Nb is not as effective at back-bonding to the carbon monoxide π^* orbitals as is Ta. The structure of $\text{Nb}(\text{CO})_4(\eta^5\text{-C}_5\text{H}_5)$ has been reported although disorder of the cyclopentadienyl ring in the structure of this parent compound appears to have introduced significant uncertainties in the Nb–CO bond lengths making comparisons with the present structures difficult [19,20]. The structures presented here are the first high quality structures of this class of niobium and tantalum compounds.

The present work has developed synthetic routes to hitherto unavailable ring functionalized derivatives of niobium and tantalum thus opening up the chemistry of these materials to elaboration and expanded application. Work on the synthesis of homo- and heterobimetallic derivatives of niobium and tantalum tetracarbonyl complexes is presently underway in our laboratory and will be reported in the near future.

3. Experimental

All operations were carried out under a nitrogen or argon atmosphere using standard Schlenk, vacuum or dry box techniques. Nitrogen was deoxygenated with activated BTS catalyst and dried with molecular sieves. Tetrahydrofuran and pyridine were predried over sodium wire and KOH respectively. Pyridine, petroleum ether and dichloromethane were distilled under nitrogen from calcium hydride. Ethyl ether, tetrahydrofuran, benzene and toluene were distilled under nitrogen from NaK. Fisher brand Fluorosil was deoxygenated by placing it under vacuum for 24 h then stored under nitrogen. Tantalum pentachloride and niobium pentachloride were purchased from Strem Chemicals and purified by sublimation. Sodium indenyl, $\text{NaC}_5\text{H}_4\text{C}(\text{=O})\text{H}$, $\text{NaC}_5\text{H}_4\text{C}(\text{=O})\text{Me}$, $\text{NaC}_5\text{H}_4\text{CO}_2\text{Me}$, $\text{NaC}_5\text{H}_4\text{CO}_2\text{Et}$, $\text{NaC}_5\text{H}_4\text{C}(\text{=O})\text{C}_6\text{H}_5$, $\text{LiC}_5\text{H}_4\text{C}(\text{CH}_3)=\text{CH}_2$, and

$\text{TMSC}_5\text{H}_4\text{CO}_2\text{Me}$ compounds were prepared as described by literature methods [21–23]. Sodium and lithium salts were isolated and stored as solids. Carbon monoxide was reagent grade and used without further purification.

Elemental analyses were performed by Desert Analytics of Tucson, AZ. IR spectra were recorded in a NaCl solution cell with dichloromethane using a Digilab Qualimatic FT-IR Spectrometer. ^1H and ^{13}C NMR spectra were recorded on either an IBM 300 MHz or a Bruker 200 MHz NMR Spectrometer. High pressure reactions were carried out in a 300 ml Parr stirred reactor.

3.1. Preparation of $\text{Na}[\text{Nb}(\text{CO})_6] \cdot \text{THF}$, **1**

The following procedure is a modification of that reported by Calderazzo and Pampaloni. Niobium pentachloride, 6.3 g (.023 mol), magnesium, 2.3 g (0.095 mol) and zinc, 2.3 g (0.035 mol) were loaded into a 300 ml Parr bomb in the glove box. Freshly distilled pyridine, 220 ml, was transferred into the bomb via canula. After sealing, the bomb was pressurized with carbon monoxide (1700 to 1900 psi) while being heated to 55°C. The mixture was stirred for 4 h during which the pressure was periodically reestablished. The dark brown contents of the bomb were poured into a 250 ml Schlenk flask under a flow of nitrogen. The flask was placed in a hot water bath and the solvent removed using a liquid nitrogen trap to give a grey powder. A 1.9M aqueous solution of NaOH (90 ml) was purged with nitrogen and added to the powder while stirring. After cooling, nitrogen purged ethyl ether (120 ml) was added to the flask and allowed to slowly stir over the solution for one hour before being removed via canula. A second volume of ether was added and stirred for 4 h and a third for 12 h. The combined ether extracts were thoroughly dried using a warm water bath and 70 ml of THF was added precipitating $\text{Na}[\text{Nb}(\text{CO})_6] \cdot \text{THF}$ as a yellow solid. Further precipitate could be encouraged by storing the solution at -80°C and filtering while cold. The yellow solid was placed under dynamic vacuum at least 1 h (excess drying will result in decomposition to a black pyrophoric solid) to yield 5.1 to 6.0 g of **1** as a light sensitive, pyrophoric solid. IR bands proved to be identical to those previously reported. Yield: 60 to 72%.

3.2. Preparation of $\text{Na}[\text{Ta}(\text{CO})_6] \cdot \text{THF}$, **2**

Tantalum pentachloride, 6.6 g (0.018 mol), magnesium, 2.1 g (0.086 mol) and zinc, 2.1 g (0.032 mol) were loaded into a 300 ml bomb in the glove box. Freshly distilled pyridine, 220 ml, was transferred into the bomb via canula. After sealing, the bomb was pressurized with carbon monoxide (1700 to 1800 psi)

and heated to 60°C. The mixture was stirred for 10 h. The reaction was worked-up as described for $\text{Na}[\text{Nb}(\text{CO})_6] \cdot \text{THF}$ resulting in 3.70 g of orange solid. Although sensitive to light and loss of coordinated THF, **2** was found to be somewhat less sensitive to decomposition than its niobium analog. IR bands were identical to those previously reported. Yield: 43 to 45%.

3.3. Preparation of $\text{NaC}_5\text{H}_4\text{COCH}_2\text{C}_6\text{H}_5$, **5**

To freshly prepared sodium cyclopentadienide, 0.18 mol, from Na dispersion and freshly cracked cyclopentadiene in THF, was added ethyl phenylacetate, 30 g (0.18 mol). After refluxing the reaction mixture overnight the THF was removed under vacuum. Addition of ethyl ether to the resulting gummy mass and trituration resulted in formation of a tan, crystalline solid. Removal of the ethyl ether by filter stick followed by washing with additional ethyl ether and removal of residual solvent under nitrogen gave **5** as a tan solid. $^1\text{H NMR}$: (D_2O) δ 7.00–6.91 (m, 5H, Ph), 6.44 (br s, 1H, Cp), 6.33 (br s, 1H, Cp), 5.91 (br s, 1H, Cp), 5.86 (br s, 1H, Cp), 3.63 (s, 2H, CH_2). $^{13}\text{C NMR}$: (D_2O) δ 190.9 (CO), 141.8 (*ipso* Ph), 131.8 (Ph), 131.4 (Ph), 129.0 (*p*-Ph), 125.6 (*ipso* Cp), 121.0 (2 C, Cp), 119.1 (Cp), 116.2 (Cp), 46.8 (CH_2) Yield: 35 g, 93%.

3.4. Preparation of $\text{TIC}_5\text{H}_4\text{COCH}_2\text{C}_6\text{H}_5$, **6**

5, 7.4 g (36 mmol), was taken up in dry ethanol (50 ml) and thallium ethoxide, 9.2 g, was added dropwise with stirring. A tan gum precipitated which formed a tan solid upon trituration with ethyl ether and petroleum ether. Yield: 12.4 g, 89%. $^1\text{H NMR}$: ($\text{DMSO}-d_6$) 7.23–7.13 (m, 5H, Ph), 6.34 (AA'BB', 2H, Cp), 5.73 (AA'BB', 2H, Cp), 3.79 (s, 2H, CH_2). $^{13}\text{C NMR}$: ($\text{DMSO}-d_6$) 189.6 (CO), 138.6 (*ipso* Ph), 129.3 (*o*-Ph), 127.9 (*m*-Ph), 125.6 (*p*-Ph), 123.8 (*ipso* Cp), 112.5 (Cp), 112.1 (Cp), 45.4 (CH_2).

3.5. Preparation of $(\eta^5\text{-C}_5\text{H}_4\text{COCH}_2\text{C}_6\text{H}_5)\text{Mn}(\text{CO})_3$, **7**

$\text{Ti}(\text{C}_5\text{H}_4\text{COCH}_2\text{C}_6\text{H}_5)$, 1.93 g (5.0 mmol), and $\text{BrMn}(\text{CO})_5$, 1.37 g (5.0 mmol), were taken up in benzene and refluxed overnight. The yellow reaction mixture was filtered through Celite and the solvent removed. Chromatography of the residue on an alumina column with 4:1 petroleum ether:dichloromethane as an eluant yielded a light yellow band that was shown by IR to be $\text{Mn}_2(\text{CO})_{10}$. Continued elution recovered an orange band that gave an orange oil that slowly converted to give 1.19 g of **7** as a crystalline solid. M.p.: 166–168°C. IR (CH_2Cl_2): 2031 (s), 1951 (s), 1686 (m, ketone) cm^{-1} . $^1\text{H NMR}$ (CDCl_3) δ 7.33 (m, 5H, Ph), 5.43 (AA'BB', 2H, Cp), 4.83 (AA'BB', 2H, Cp), 3.90 (s,

2H, CH_2). $^{13}\text{C NMR}$ (CDCl_3) δ 222.7 (Mn–CO), 194.9 (ketone CO), 133.8 (*ipso* Ph), 129.3 (Ph), 128.8 (Ph), 127.2 (Ph), 91.2 (*ipso* Cp), 86.9 (Cp), 83.7 (Cp), 46.3 (CH_2). Anal. calcd for $\text{C}_{16}\text{H}_{11}\text{O}_4\text{Mn}$: C, 59.64; H, 3.42. Found: 59.65; H, 3.42. Yield: 77%.

3.6. Preparation of $(\eta^5\text{-C}_5\text{H}_4\text{CO}_2\text{Me})\text{Nb}(\text{CO})_4$, **8**

A 100 ml Schlenk flask was loaded with $\text{Na}[\text{Nb}(\text{CO})_6] \cdot \text{THF}$, 1.2 g (3.37 mmol), and placed under an atmosphere of carbon monoxide (8 psi). To this flask was added THF (25 ml) while rapidly stirring. In a Schlenk addition funnel a slurry was made containing finely divided $\text{Cu}(\text{I})\text{Cl}$, 0.67 g (6.74 mmol), and 20 ml THF under a carbon monoxide atmosphere. The $\text{Cu}(\text{I})\text{Cl}$ solution was added to the flask containing the hexacarbonyl at room temperature producing an almost immediate color change and moderate CO evolution. After 1 h, $\text{NaC}_5\text{H}_4\text{CO}_2\text{Me}$, 0.75 g (5.12 mmol), in 20 ml of THF was added to the dark brown solution. The resultant mixture was stirred for no more than 1 h and the solvent evaporated. Benzene (20 to 30 ml) was added to the resultant tacky brown solid, and the mixture stirred for several minutes. The mixture was passed through a 3×5 cm plug of silica and the resulting red band collected and solvent removed. The crude material was sublimed to give a product contaminated with an organic oil. The crude material was washed or recrystallized from petroleum ether prior to a second sublimation. Solutions of this compound are air sensitive, but the crystalline solids are stable to air for extended periods. M.p.: 74–77°C; dec. 160°C. IR (CH_2Cl_2): 2041 (s), 1929 (vs), 1722 (m, ester) cm^{-1} . $^1\text{H NMR}$ (CDCl_3) δ 6.14 (br s, 2H, Cp), 5.60 (br s, 2H, Cp), 3.77 (s, 3H, OCH_3). $^{13}\text{C NMR}$ (CDCl_3) δ 165.55 (CO(=O)Me), 96.67 (br, Cp), 52.01 (CH_3). Neither the *ipso* Cp carbon nor the Nb–CO was observed. Anal. calcd for $\text{C}_{11}\text{H}_7\text{O}_6\text{Nb}$: C, 40.27; H, 2.15. Found: C, 40.00, H, 2.06. Yield: 36%.

A second synthesis utilizing the TMS derivative of $\text{C}_5\text{H}_4\text{CO}_2\text{CH}_3$ resulted in a similar yield of metallated product.

Compounds **9** through **19** were prepared as previously described for **8**.

3.7. $(\eta^5\text{-C}_5\text{H}_4\text{CO}_2\text{Me})\text{Ta}(\text{CO})_4$, **9**

M.p.: 71–75°C; dec. 168°C. IR (CH_2Cl_2): 2037 (s), 1921 (vs), 1727 (m, ester) cm^{-1} . $^1\text{H NMR}$ (CDCl_3) δ 6.13 (AA'BB', 2H, Cp), 5.62 (AA'BB', 2H, Cp), 3.78 (s, 3H, CH_3). $^{13}\text{C NMR}$ (CDCl_3) δ 242 (br, CO), 164.81 (CO₂Me), 100.44 (*ipso* Cp), 96.60 (Cp), 95.38 (Cp), 52.18 (CH_3). Anal. calcd for $\text{C}_{11}\text{H}_7\text{O}_6\text{Ta}$: C, 31.75; H, 1.70. Found: C, 31.88; H, 1.72. Yield: 35%.

3.8. $(\eta^5\text{-C}_5\text{H}_4\text{CO}_2\text{Et})\text{Nb}(\text{CO})_4$, **10**

M.p.: 47°C. IR (CH_2Cl_2): 2038 (s), 1928 (vs), 1717 (m, ester) cm^{-1} . $^1\text{H NMR}$ (CDCl_3) δ 6.13 (br, s, 2H, Cp), 5.59 (br s, 2H, Cp), 4.21 (q, 2H, $J = 7.1$, CH_2), 1.26 (t, 3H, $J = 7.1$ Hz, CH_3). $^{13}\text{C NMR}$ (CDCl_3) δ 164.76 (CO_2Et), 102.0 (br, *ipso* Cp), 97.42 (br, Cp), 61.03 (CH_2), 14.16 (CH_3). Anal. calcd for $\text{C}_{12}\text{H}_9\text{O}_6\text{Nb}$: C, 42.13; H, 2.65. Found: C, 42.19; H, 2.59. Yield: 37%.

3.9. $(\eta^5\text{-C}_5\text{H}_4\text{CO}_2\text{Et})\text{Ta}(\text{CO})_4$, **11**

M.p.: 61–63°C. IR (CH_2Cl_2): 2036 (s), 1921 (vs), 1721 (m, ester) cm^{-1} . $^1\text{H NMR}$ (CDCl_3) δ 6.12 (AA'BB', 2H, Cp), 5.61 (AA'BB', 2H, Cp), 4.24 (q, 2H, $J = 7.1$, CH_2), 1.27 (t, 3H, $J = 7.1$, CH_3). $^{13}\text{C NMR}$ (CDCl_3) δ 242.10 (CO), 164.26 (CO_2Et), 100.80 (*ipso* Cp), 96.67 (Cp), 95.25 (Cp), 61.16 (CH_2), 14.07 (CH_3). Anal. calcd for $\text{C}_{12}\text{H}_9\text{O}_6\text{Ta}$: C, 33.51; H, 1.93. Found: C, 33.43; H, 1.93. Yield: 37%.

3.10. $(\eta^5\text{-C}_5\text{H}_4\text{C}(\text{=O})\text{Me})\text{Nb}(\text{CO})_4$, **12**

M.p.: 94–96°C; dec. 118°C. IR (CH_2Cl_2): 2040 (s), 1930 (vs), 1684 (w, acetyl) cm^{-1} . $^1\text{H NMR}$ (CDCl_3) δ 6.03 (br s, 2H, Cp), 5.61 (br s, 2H, Cp), 2.24 (s, 3H, CH_3). $^{13}\text{C NMR}$ (CDCl_3) δ 193.85 ($\text{C}(\text{=O})\text{Me}$), 110 (br, *ipso* Cp), 98.80 (br, Cp), 95.91 (br, Cp), 26.29 (CH_3). Anal. calcd for $\text{C}_{11}\text{H}_7\text{O}_5\text{Nb}$: C, 42.34; H, 2.26. Found: C, 42.23; H, 2.28. Yield: 24%.

3.11. $(\eta^5\text{-C}_5\text{H}_4\text{C}(\text{=O})\text{Me})\text{Ta}(\text{CO})_4$, **13**

Dec.: 109°C. IR (CH_2Cl_2): 2037 (s), 1922 (vs), 1687 (m, ester) cm^{-1} . $^1\text{H NMR}$ (CDCl_3) δ 6.03 (m, 2H, Cp), 5.65 (m, 2H, Cp), 2.25 (s, 3H, CH_3). $^{13}\text{C NMR}$ (CDCl_3) δ 203.6 ($\text{C}(\text{=O})\text{Me}$), 108.8 (*ipso* Cp), 97.5 (Cp), 97.5 (Cp), 96.2 (Cp), 94.0 (Cp), 26.3 (CH_3). Anal. calcd for $\text{C}_{11}\text{H}_7\text{O}_5\text{Ta}$: C, 33.02; H, 1.76. Found: C, 32.93; H, 1.66. Yield: 8%.

3.12. $(\eta^5\text{-C}_5\text{H}_4\text{C}(\text{=O})\text{C}_6\text{H}_5)\text{Nb}(\text{CO})_4$, **14**

M.p.: 92–95°C with decomp. IR (CH_2Cl_2): 2040 (s), 1930 (vs), 1653 (w, ketone) cm^{-1} . $^1\text{H NMR}$ (CDCl_3) δ 7.73 (2H, *o*-Ph), 7.56 (1H, *p*-Ph), 7.45 (2H, *m*-Ph), 6.18 (br, 2H, Cp), 5.71 (br, 2H, Cp). $^{13}\text{C NMR}$ (CDCl_3) δ 191.29 ($\text{C}(\text{=O})\text{C}_6\text{H}_5$), 137.9 (*ipso* Ph), 132.4 (*p*-Ph), 128.5 (*o*-Ph), 128.1 (*m*-Ph), 109.8 (br, *ipso* Cp), 97.7 (br, Cp). Anal. calcd for $\text{C}_{16}\text{H}_9\text{O}_5\text{Nb}$: C, 51.36; H, 2.42. Found: C, 51.15; H, 2.25. Yield: 10%.

3.13. $(\eta^5\text{-C}_5\text{H}_4\text{C}(\text{=O})\text{C}_6\text{H}_5)\text{Ta}(\text{CO})_4$, **15**

M.p.: 105–107°C with decomp. IR (CH_2Cl_2): 2036 (s), 1921 (vs), 1656 (w, ketone) cm^{-1} . $^1\text{H NMR}$ (CDCl_3) δ 7.73 (m, 2H, *o*-Ph), 7.57 (m, 1H, *p*-Ph), 7.46 (m, 2H, *m*-Ph), 6.17 (AA'BB', 2H, Cp), 5.72 (AA'BB', 2H, Cp). $^{13}\text{C NMR}$ (CDCl_3) δ 241.6 (CO), 190.7 ($\text{C}(\text{=O})\text{C}_6\text{H}_5$),

137.6 (*ipso* Ph), 132.5 (*p*-Ph), 128.6 (*o*-Ph), 128.1 (*m*-Ph), 108.7 (*ipso* Cp), 97.2 (Cp), 96.17 (Cp). Anal. calcd for $\text{C}_{16}\text{H}_9\text{O}_5\text{Ta}$: C, 41.58; H, 1.96. Found: C, 41.69; H, 1.89. Yield: 23%.

3.14. $(\eta^5\text{-C}_5\text{H}_4\text{C}(\text{=O})\text{CH}_2\text{C}_6\text{H}_5)\text{Nb}(\text{CO})_4$, **16**

M.p.: 132°C with decomp. IR (CH_2Cl_2): 2040 (s), 1931 (vs), 1686 (w, ketone) cm^{-1} . $^1\text{H NMR}$ (CDCl_3) δ 7.36–7.23 (m, 5H, Ph), 6.11 (br s, 2H, Cp), 5.64 (br s, 2H, Cp), 3.89 (s, 2H, CH_2). $^{13}\text{C NMR}$ (CDCl_3) δ 194.0 ($\text{C}(\text{=O})\text{CH}_2\text{C}_6\text{H}_5$), 135.0 (*ipso* Ph), 129.2 (Ph), 128.8 (Ph), 127.2 (Ph), 98.0 (br, Cp), 95.0 (br, Cp), 46.0 (CH_2). *Ipso* Cp carbon not observed. Anal. calcd for $\text{C}_{17}\text{H}_{11}\text{O}_5\text{Nb}$: C, 52.86; H, 2.86. Found: C, 52.65; H, 2.75. Yield: 24%.

3.15. $(\eta^5\text{-C}_5\text{H}_4\text{C}(\text{=O})\text{CH}_2\text{C}_6\text{H}_5)\text{Ta}(\text{CO})_4$, **17**

M.p.: 149°C with decomp. IR (CH_2Cl_2): 2037 (s), 1922 (vs), 1689 (m, ketone) cm^{-1} . $^1\text{H NMR}$ (CDCl_3) δ 7.36–7.20 (m, 5H, Ph), 6.10 (AA'BB', 2H, Cp), 5.66 (AA'BB', 2H, Cp), 3.90 (s, 2H, CH_2). $^{13}\text{C NMR}$ (CDCl_3) δ 241.4 (br, CO), 193.4 ($\text{C}(\text{=O})\text{CH}_2\text{C}_6\text{H}_5$), 133.7 (*ipso* Ph), 129.3 (Ph), 128.8 (Ph), 127.3 (Ph), 108.3 (*ipso* Cp), 97.4 (Cp), 94.3 (Cp), 45.9 (CH_2). Anal. calcd for $\text{C}_{17}\text{H}_{11}\text{O}_5\text{Ta}$: C, 42.88; H, 2.33. Found: C, 42.96; H, 2.38. Yield: 26%.

3.16. $(\eta^5\text{-C}_5\text{H}_4\text{C}(\text{CH}_3)=\text{CH}_2)\text{Nb}(\text{CO})_4$, **18**

M.p.: 68–69°C; 158°C decomp. IR (CH_2Cl_2): 2033 (s), 1919 (vs) cm^{-1} . $^1\text{H NMR}$ (CDCl_3) δ 5.82 (br, 2H, Cp), 5.51 (br, 2H, Cp), 5.22 (s, 1H, CH_2), 4.81 (t, 1H, CH_2), 1.91 (q, CH_3). $^{13}\text{C NMR}$ (CDCl_3) δ 136.0 ($\text{C}(\text{CH}_3)=\text{CH}_2$), 111.1 (CH_2), 94.6 (br, Cp), 21.1 (s, CH_3). Anal. calcd for $\text{C}_{12}\text{H}_9\text{O}_4\text{Nb}$: C, 46.48; H, 2.93. Found: C, 46.49; H, 3.04. Yield: 32%.

3.17. $(\eta^5\text{-C}_5\text{H}_4\text{C}(\text{CH}_3)=\text{CH}_2)\text{Ta}(\text{CO})_4$, **19**

M.p.: 87–88°C; 172°C decomp. IR (CH_2Cl_2): 2030 (s), 1911 (vs) cm^{-1} . $^1\text{H NMR}$ (CDCl_3) δ 5.81 (AA'BB', 2H, Cp), 5.52 (AA'BB', 2H, Cp), 5.22 (s, 1H, CH_2), 4.86 (s, 1H, CH_2), 1.91 (s, 3H, CH_3). $^{13}\text{C NMR}$ (CDCl_3) δ 244.77 (br, CO), 135.7 ($\text{C}(\text{CH}_3)=\text{CH}_2$), 117.0 (*ipso* Cp), 111.7 (CH_2), 93.1 (Cp), 91.0 (Cp), 21.0 (CH_3). Anal. calcd for $\text{C}_{12}\text{H}_9\text{O}_4$; Ta: C, 36.20; H, 2.28. Found: C, 36.19; H, 2.22. Yield: 26%.

3.18. $(\eta^5\text{-C}_9\text{H}_7)\text{Nb}(\text{CO})_4$, **20**

The procedure as outlined in the preparation of **8** up to the addition of the $\text{Cu}(\text{I})\text{Cl}$ was followed. 20 min after the $\text{Cu}(\text{I})\text{Cl}$ addition the flask was placed in a warm water bath (60°C) and gently heated until disappearance of the peak at 2093.7 cm^{-1} . The NaC_9H_7 was then added and the preparation as outlined in **8** was

continued. This step eliminates the need for recrystallization and a second sublimation. M.p.: 111–113°C; 149°C decomp. IR (CH₂Cl₂): 2039 (s), 1921 (vs) cm⁻¹. ¹H NMR (CDCl₃) δ 7.52 (m, 2H, C₆H₄), 7.03 (m, 2H, C₆H₄), 6.06 (d, 2H, C-1 and C-3), 5.75 (t, 1H, C-2). ¹³C NMR (CDCl₃) δ 124.7 (C₆H₄), 124.2 (C₆H₄), 114.5 (*ipso*), 97.0 (Cp), 83.6 (Cp). Anal. calcd for C₁₃H₇O₄Nb: C, 48.78; H, 2.20. Found: C, 48.99; H, 2.10. Yield: 41%.

3.19. (η⁵-C₉H₇)Ta(CO)₄, **21**

Compound **21** was prepared as described for **20**. Dec.: 169°C. IR (CH₂Cl₂): 2030 (s), 1912 (vs) cm⁻¹. ¹H NMR (CDCl₃) δ 7.52 (m, 2H, C₆H₄), 7.07 (m, 2H, C₆H₄), 6.11 (d, 2H, C-1 and C-3), 5.77 (t, 1H, C-2). ¹³C NMR (CDCl₃) δ 243.9 (CO), 125.0 (C₆H₄), 124.9 (C₆H₄), 113.6 (*ipso*), 95.7 (Cp), 82.1 (Cp). Anal. calcd for C₁₃H₇O₄Ta: C, 38.26; H, 1.73. Found: C, 38.19; H, 1.65. Yield 34%.

4. Crystallographic studies

Crystal, data collection, and refinement parameters are given in Table 1. The systematic absences in the diffraction data are uniquely consistent for the reported space groups. Structures of **9** and **16** were solved using direct methods. The atomic coordinates of **9** were used as a trial solutions for the isomorphous niobium analogue, **8**. The structures were completed by subsequent difference Fourier synthesis and refined by full-matrix least-squares procedures. Semi-empirical absorption corrections were applied. All non-hydrogen atoms were refined with anisotropic displacement coefficients. Hydrogen atoms were treated as idealized contributions.

All software and sources of the scattering factors are contained in the SHELXTL PLUS (4.2) or SHELXTL (5.3) program libraries (G. Sheldrick, Siemens XRD, Madison, WI).

Acknowledgements

We sincerely thank Professor Calderazzo and Dr. Pampaloni for their generous hospitality, kind sugges-

tions and detailed explanations of their original syntheses of the niobium and tantalum carbonyl complexes that form the basis of this paper. We thank the University of Idaho Research Foundation for a SEED Grant for this research.

References

- [1] S.C. Tenhaeff, D.R. Tyler, *Organometallics* 10 (1991) 473.
- [2] S.C. Tenhaeff, D.R. Tyler, *Organometallics* 10 (1991) 1116.
- [3] J. Allshouse, B.B. Kaul, M. Rakowski DuBois, *Organometallics* 13 (1994) 28.
- [4] L.L. Lopez, J. Gabay, R.C. Haltiwanger, J. Allshouse, J.J. Casewit, M. Rakowski DuBois, *Organometallics* 12 (1993) 4764.
- [5] A. Avey, D.R. Tyler, *Organometallics* 11 (1992) 3856.
- [6] D.E. Wigley, S.D. Gray, Niobium and tantalum, in: E. Abel, G. Wilkinson, F.G.A. Stone (Eds.), *Comprehensive Organometallic Chemistry II*, Elsevier, Oxford, 1995.
- [7] J.A. Labinger, Niobium and tantalum, in: E. Abel, G. Wilkinson, F.G.A. Stone (Eds.), *Comprehensive Organometallic Chemistry II*, Elsevier, Oxford, 1982, and references therein.
- [8] M.L.H. Green, A.K. Hughes, *J. Chem. Soc. Dalton Trans.* (1992) 527.
- [9] W.A. Herrman, H. Biersack, *J. Organomet. Chem.* 191 (1980) 397.
- [10] R.P.M. Werner, A.H. Filbey, S.A. Manastyrskij, *Inorganic Chem.* 3 (1964) 298.
- [11] M. Hoch, D. Rehder, *Chem. Ber.* 121 (1988) 1541.
- [12] B.V. Lokshin, E.B. Rusach, Z.P. Valueva, A.G. Ginzburg, N.E. Kolobova, *J. Organomet. Chem.* 102 (1975) 535.
- [13] F. Calderazzo, M. Castellani, G. Pampaloni, P.F. Zanazzi, *J. Chem. Soc. Dalton Trans.* (1985) 1989.
- [14] M. Pasquali, C. Floriani, A. Gaetani-Manfredotti, *Inorg. Chem.* 20 (1981) 3382.
- [15] W.P. Hart, D.W. Macomber, M.D. Rausch, *J. Am. Chem. Soc.* 102 (1980) 1196.
- [16] T.E. Bitterwolf, S.S. Jones, M.D. Rausch, *J. Organometal. Chem.* 396 (1990) 279.
- [17] D.W. Macomber, W.P. Hart, M.D. Rausch, *Adv. Organomet. Chem.* 21 (1982) 19.
- [18] R.C. Kerber, B. Waldbaum, *Organometallics* 14 (1995) 4742.
- [19] W.A. Herrmann, Q. Kalcher, H. Biersack, I. Bernal, M. Creswick, *Chem. Ber.* 114 (1981) 3558.
- [20] H.W. Baird, PhD Thesis, Univ. Wisconsin, 1963.
- [21] M.D. Rausch, W.P. Hart, D. Shihua, *J. Organometal. Chem.* 282 (1985) 111.
- [22] M.D. Rausch, M. Ogasa, D.T. Mallin, D.W. Macomber, *J. Organometal. Chem.* 405 (1991) 41.
- [23] M.D. Rausch, S. Barry, A. Kucht, H. Kucht, *J. Organometal. Chem.* 489 (1995) 195.